



**THE INFLUENCE OF FINANCIAL LITERACY,
THE IMAGE OF DESTINATION, THE SOCIAL MEDIA
AGAINST THE INTEREST OF VISITING LOCAL TOURISTS
THROUGH THE MEDIATION OF THE EMOTIONAL EXPERIENCE**

**Ika Barokah Suryaningsihⁱ,
Sumani**

Department of Management,
Faculty of Economics and Business,
University of Jember, Indonesia

Abstract:

This study aims to determine the influence of financial literacy, the image of destination, the social media against the interest of visiting local tourists through the mediation of the emotional experience of visitors. The population in this study is all domestic visitors of Telaga Sarangan Natural Attraction with purposive sampling technique as many as 120 respondents. The tool of analysis used is path analysis to test each of the relationships between the research variables. The results showed that the visitor's financial literacy, the image of destination, and the social media significantly influence the emotional experience of visitors. In addition, the visitor's financial literacy, the image of destination and the social media also directly affects the increase of interest to revisit the destination in the future. On the other hand, the emotional experience has a significant effect on the interest to revisit the destination in the future, so the relationship between the emotional experiences in a positive manner can increase the visitor's interest to revisit Telaga Sarangan Natural Attraction.

Keywords: financial literacy, the image of destination, social media, interest of visiting, a tourist destination

1. Introduction

Experience that is felt when visiting a tourist spot also into consideration the current visitors in choosing a destination. So that the visitor experience (customer experience) need to be attention of the managers or marketers in satisfying its customers so that they can win the competition. According to Frederick & Hariwan (2016) visitor experience (customer experience) is a bond of rational and emotional that occur because

ⁱ Correspondence: email barokah.feb@unej.ac.id

of a response to a particular stimulus by optimizing sense (sensory), feel (emotional), think (cognitive), act (action), and relate (relationship) in marketing efforts before and after purchase, the exchange of information and emotional bond. Ye, Xiao, & Zhou (2019) and Zatori, Smith, & Puczko (2018) describe that the experience of travellers consists of three aspects, namely experience of functional, emotional and authentic.

The influence of the experience of visitors to the interests to revisit the same spot is not in spite of the economic conditions of the visitors. Knowledge and ability in financial management can determine the priority of spending decisions (Chen & Volpe, 1998; L. Remund, 2010; Lewis Mandell, 2008). Financial literacy is the knowledge and skills associated with the understanding of the concepts and risks and the skills to be able to make effective decisions in the context of the financial to improve the financial well-being, both individual and social, and can participate in the community environment (L. Remund, 2010; L. Mandell & K. Klein, 2007). Based on the ability of financial management then each person is ultimately able to allocate its income for the needs of the travelling.

Tourists are considered important for assessing a destination because the tourists or visitors are the buyer or the connoisseur of services. Tourists judge a destination through belief and perception (Chieh, King, & Lee, 2018; Ying, Wei, Wen, Wang, & Ye, 2018), which then can be called as the image of destination. The image of the destination according to (Hanif, Kusumawati, & Mawardi, 2016) is the belief/knowledge about a tourism destination and what is perceived by the tourists during travelling. Knowledge of the image of a tourist destination can be obtained from a variety of medias one of them is social media.

Media users of the internet in Indonesia continues to increase which reached the figure of 63 million people, of which 95 percent use for social media, it is based on data from the ministry of communication and information. According to Abrams (2017) social media is a media where users easily participate in, share and create messages, including blogs, social networking, wiki/online encyclopaedia, virtual forums, including virtual worlds. Because of this, social media is a promotion tool that may be effective in informing the attractions to be more widely known amid tight business competition in the tourism industry (Hamzah, 2013).

Tourism is one important sector for Indonesia. The components of the natural wealth and culture become an important part in Indonesia's tourism. Natural wealth makes Indonesia tourism favored by domestic visitors and abroad. In the today's modern business tourism began to be widely developed, among others, natural tourism, nautical tourism, cultural tourism, agricultural tourism, pilgrimage tourism, heritage tourism, ecotourism and etc. Public interest in nature sparked a lot of development of the place of natural tourist destinations, so as to make visitors have a lot of choice in determining the place of natural tourist destinations. One of natural attractions placed at East Java province that is attractive to tourists is natural attractions called Telaga Sarangan Natural Attraction in Magetan Regency. Telaga Sarangan Natural Attraction is a natural attraction that offers a beautiful natural landscape, the

strawberry garden, horse riding, a wide variety of culinary, tourism market, market fresh vegetable, vehicle speed board and other. Visitors are pampered with a view of the beautiful lake, the fresh air while you eat the presented food. Telaga Sarangan Natural Attraction is the tourism spot that first deserted of tourists, has now turned into one of main tourism object in East Java particularly to Magetan Regency with lots of visitors. Based on theory and the existing empirical gap, this research is aimed to know the influence of financial literacy, the image of destination, the social media against the interest to visit of the local tourists through the mediation of the emotional experience of visitors.

2. Literature Review

2.1 Financial Literacy to Emotional Experience and Interest to Revisit

Financial literacy is the level of knowledge, skills, and confidence of the community related to financial institution as well as the products-services which is poured in the parameters of the size of the index. Financial literacy can help give you an understanding of how to manage the finances and provides an overview of the opportunities in order to achieve a better life in the future. Financial literacy consists of indicators: (a) careful comparison price before buying; (b) search info related to the development of the economy; (c) make a budget expenses in and out; and (d) the expenses of each month (Chen & Volpe, 1998; Lewis Mandell, 2008).

According to Yuni & Finardi (2016), visitor experience/customer experience is defined as experience obtained by the consumers either directly or indirectly regarding the process of service, the company, the facilities and how a consumer interacts with the company and with other consumers. This in turn will make the response in cognitive, emotion and consumer behavior and leave the memories of consumers about the experience during and after the visit. According to Bora, Bilgihan, Haobin, Buonincontri, & Okumus (2018); Frederick & Hariwan (2016); and Yuni & Finardi (2016), with the existing of the customer experience, customers will be able to distinguish the products and services one with the other because they can feel and gain experience directly through five approaches (sense, feel, think, act, relate), both before and when they consume the product or service. Visitors experience stay at the three levels i.e. functional, emotional, and authentic experience (Ye et al., 2019). Emotional experience much woke up from someone who is looking for fun as well as people travelling. Tourists will revisit the same tourist destination if only they have the financial ability that is limited, but remains scheduled the needs to travel there.

Therefore, the hypothesis posed is as follows.

H1: Financial Literacy affects the emotional experience.

H4: Financial Literacy affects the interest to revisit.

2.2 Destination Image to the Emotional Experience and Interest to Revisit

Destination image according to Hanif et al. (2016) is the trust which is owned by the business regarding the products or services that tourists buy or will buy. The image of destination is not always formed from experience or fact, but can be formed so that it becomes a factor of motivation or a strong driving force for the travel of tourists to a tourism destination. This is corroborated by previous research that the image of the object significantly influences the emotional experience (Ye et al., 2019).

Destination image according to Wibowo, Sazali, & Riva (2016) is the trust which is owned by the business regarding the products or services that tourists buy or will buy. Destination image is not always formed from experience or fact, but can be formed so that it becomes a factor of motivation or a strong driving force for the travel of tourists to a tourism destination. This is corroborated by previous research that the image of a destination affects the intention to visit the birthday business. Based on the description above then the hypothesis posed is as follows:

H2: Image of destination allegedly affects the emotional experience.

H5: Image of destination allegedly affects the interest to revisit.

2.3 Social Media to Emotional Experience and the Interest to Revisit

According to Hamzah (2013) and Kotler (2000) social media is online content created by using the technology of publishing that is a very easy and scalable, the most important of these technologies is the shift in ways of knowing people, read and share stories and find information and content. One way of increasing the promotion of tourism is to attract more tourists to revisit the tourist destination in the future. Therefore, the increase in innovation in the field of promotion should be carried out. One simple innovation that can be done to improve the promotion is to perform interactive promotional through the phenomenon of message delivery in social media like a personal blog, then the booming use of Facebook, Twitter, and various similar applications. This of course also happens in Indonesia. Every day more and more internet users create an account in the applications such as Facebook, Twitter, Instagram, path, and blog (Hamzah, 2013). The results of the review of tourist attraction in social media provide an understanding for the users of social media in building their emotional experience, of course this is what brings the tourists will revisit the same tourist attractions.

According to Hamzah (2013) and Wakefield & Wakefield (2018), social media is a means for consumers to share information -text, image, audio, and video- with each other and with companies and vice versa. As the research conducted by Setiyaningtiyas & Hasan (2015) that the electronic word of mouth have a significant effect on social media Facebook against the decision to visit Desa Wisata Nglanggeran Gunung Kidul Yogyakarta. This proves that social media can have an effect on the interest to revisit of the tourists. Based on the above description then the hypothesis posed is as follows:

H3: Social media affect the emotional experience.

H6: Social media affect the interest to revisit

2.4 Emotional Experience of Visitors to the Interest to Revisit

According to Walter cited by Rahma, You, & Yuniawati (2016), visitor experience/customer experience is defined as experience obtained by the consumers either directly or indirectly regarding the process of service, the company, the facilities and how a consumer interacts with the company and with other consumers. This in turn will make the response in cognitive, emotional and consumer behavior and leave the memories of consumers about the experience during and after the visit. With the customer experience, customers will be able to distinguish the products and services one with the other because they can feel and gain experience directly through five approaches (sense, feel, think, act, relate), both before and when they consume a product or service. Meanwhile, the emotional experience is a reflection of the presence of indicators of entertaining, educative, aesthetic, and escaping (Ye et al., 2019).

Hawkins & Coney (2001) states that there are three indicators that can form the re-buying interest namely: (a) the purchase frequency; (b) the purchase commitment; and (c) someone's recommendations. Emotional experience that is formed can be a trigger for someone visiting the same tourist attractions in the future. That social media can have an effect on the interest to revisit. Based on the above description then the hypothesis posed is as follows:

H7: Emotional experience affects the interest to revisit.

3. Material and Methods

3.1 Sample Size

The population in this study is all domestic visitors of Telaga Sarangan Natural Attraction that performs the last visit in 2017. The sampling technique used in this research is purposive sampling, with criteria: (d) Travelers who have visited Telaga Sarangan Natural Attraction at least two times; (b) Respondents aged 18 years according to the assumed that the respondents have been able to and understand and can respond to each statement in questionnaire research better; and (c) Respondents who fill in the questionnaire is the respondents who are willing to fill out a questionnaire. The number of samples is equal to the number of indicators multiplied by 5 up to 10 (Ferdinand, 2006). In this study, the number of variables examined as many as three independent variables, one dependent variable, and one intervening variable so that the total overall indicator is the 15 indicators. So, the minimum number of samples in this study is a total of 120 respondents. However, in this study will include as many as 150 questionnaires. This is done as a preventive measure if there is a questionnaire that is damaged or not returned

3.2 Measurement

The type of data in this study is cross section data by using the measurement scale that is ordinal data. The primary data source in this study is taken from the questionnaires that were filled by the visitors of Telaga Sarangan Natural Attraction that meet the

criteria. The questionnaire contains statements related to the variables of the visitor experience, financial literacy, the image of destination, social media and interest to revisit in the future. In addition, the questionnaire also contains about the characteristics of the respondents in the form of gender, age, education, occupation/profession, status of the family, the means of transportation used, origin or domicile of visitors, with whom they visited and number of visits.

3.3 Data Analysis

Test of research instruments was done by using validity test Pearson Product Moment (Sugiyono, 2008) and reliability test was done using Cronbach's Alpha test (Sugiyono, 2008). Normality test of the data used in this study using the Kolmogorov-Smirnov test to establish the degree of confidence (α) of 5%. Tools of data analysis used is Path Analysis (Everitt & Hothorn, 2011), with the estimation of the influence of the causal and the position of each variable in the path either directly or indirectly. If in the t test there is a line that is not significant, it is necessary to perform re-calculation by eliminating the paths that are not significant based on trimming theory.

4. Results and Discussion

4.1 Results

4.1.1 Profile of Respondents

Table 1 below presents the data of descriptive statistics for each variable characteristic of the respondents used in this study.

Table 1: Characteristic Profile of Respondents

Description	Percentage (%)	Description	Percentage (%)
Gender		Means of transportation	
Male	40.8	Personal vehicles	68,3
Female	59.2	Public transportation	31,7
Age		Visitors' origin	
18 - 21 years old	13.4	In the city	42,5
22 - 24 years old	35	Another city	57,5
25 - 29 years old	25.9	Kinds of visit	
30 - 33 years old	18.3	Alone	13,3
> 34 years old	7.4	With friends	24,1
Level of education		With family	40
Junior high school	9.2	Rombongan	22,6
Senior high school	28.3	The intensity of the visit	
Undergraduate school (Bachelor)	44.2	2 - 5 times	18,3
Graduate school (Master)	18.3	6 - 9 times	45
Occupation		10 - 13 times	22,5
Private employees	23.3	> 14 times	14,2
Students	17.5	The purpose of the visit	
Civil servant	15	Travelling	50,8

Ika Barokah Suryaningsih, Sumani
 THE INFLUENCE OF FINANCIAL LITERACY, THE IMAGE OF DESTINATION,
 THE SOCIAL MEDIA AGAINST THE INTEREST OF VISITING LOCAL TOURISTS THROUGH
 THE MEDIATION OF THE EMOTIONAL EXPERIENCE

Self-employed	40,8	Meetings	22,5
Army/Police	3,4	Educational event	26,7

Based on table 1 in general, a lot that visiting Telaga Sarangan Natural Attraction is female with the dominant age range of 25-29 years. While most visitors who come are bachelor with a job as self-employed, and the average trip using a private vehicle for those who come from outside the Magetan Regency. Most of the visitors who come to the Telaga Sarangan Natural Attraction is coming together with family, with the intensity of visiting several times. On the other hand, the purpose of the travel is of course for pure travelling, but the other part is because of the purpose of educational tourism and also because of the work that requires them to be quarantined in a hotel in the tourist area of Telaga Sarangan Natural Attraction.

4.1.2 Measurement Model, Validity, and Reliability

The measurement of the varibale needs to be done (Sugiyono, 2008). Validity test is used to test whether an item which is a question or a statement is suitable to be used as a measuring tool for the measured variable. While the reliability test used to determine the reliability of the data. A measuring instrument can be said reliable is if such a tool gives consistent results even if it used repeatedly. Normality test data is used to determine whether the data of the population distribution is normal or not. In this study, using the Kolmogorov-Smirnov test to establish the degree of confidence (α) of 5%.

Table 2: Measurement Model, Validity, and Reliability

Variable	Item	R	Sig	Cronbach's Alpha	Kolmogorov Smirnov
FL	FL1	0,714	0,000	0,752	0,143
	FL2	0,649	0,000		
	FL3	0,606	0,000		
	FL4	0,628	0,000		
	FL5	0,586	0,000		
CD	CD1	0,855	0,000	0,859	0,138
	CD2	0,825	0,000		
SM	SM1	0,672	0,000	0,768	0,129
	SM2	0,774	0,000		
EE	EE1	0,748	0,000	0,800	0,172
	EE2	0,782	0,000		
	EE3	0,709	0,000		
	EE4	0,801	0,000		
IV	IV1	0,604	0,000	0,771	0,200
	IV2	0,707	0,000		
	IV3	0,775	0,000		

Based on table 2, it can be seen that the correlation between each indicator variable which is Financial Literacy (FL), Destination Image (DI), Social Media (SM), Emotional Experience (EE) and Interest to Revisit (IrV) shows the results of the correlation

coefficient (R-count) significantly below $\alpha=5\%$. The results of the reliability test on the variable Financial Literacy (FL) with the value of Cronbach's Alpha of 0.752. The results of the reliability test on the variable Destination Image (DI) with a value of Cronbach's Alpha of 0,859. The results of reliability test on variables of Social Media (X_3) with the value of Cronbach's Alpha of 0,768. The results of the reliability test on the variable of Emotional Experience (EE) with the value of Cronbach's Alpha of 0,800 and the results of the reliability test on the variables of Interest to Revisit (IrV) with the value of Cronbach's Alpha or r alpha of 0,771 It is proved that this research instrument in the form of questionnaire has been reliable because the r alpha value is greater than 0.60 (Ghozali, 2012). Based on the results of the Kolmogorov Smirnov test, it is known that the variable Financial Literacy (FL) has a probability value or significance of 0,143, the variable Destination Image (DI) has a probability value or significance of 0,138, the variable of Social Media (SM) has a probability value or significance of 0,129, the variable of Emotional Experience (EE) has a probability value or significance of 0,172, and the variable Interest to Revisit (IV) has a probability value or significance of 0,200. Those values are greater than the value of $\alpha=5\%$. So, it can be stated that the data in this research have normal distribution.

4.1.3 Path Analysis and Hypothesis Testing

Path analysis (Path Analysis) is part of the regression analysis used to analyze the relationship between variables, where each independent variable affects the dependent variable either directly or indirectly through one or more intermediate variables. The results of the path analysis are presented in the table as follows:

Table 3: The Results of Path Analysis of Variables

Standardized					
Direct Effect:		Beta	Sig	α	Description
FL →	EE	0,231	0,000	0,05	Significant
CD →	EE	0,338	0,002	0,05	Significant
SM →	EE	0,273	0,007	0,05	Significant
FL →	IV	0,240	0,000	0,05	Significant
CD →	IV	0,321	0,002	0,05	Significant
SM →	IV	0,247	0,007	0,05	Significant
EE →	IV	0,216	0,010	0,05	Significant
Indirect Effect:					
FL →	EE →	IV	0,049		
CD →	EE →	IV	0,073		
SM →	EE →	IV	0,058		
Total Effect:					
IV: FL→	EE →	IV	0,289		
IV: CD→	EE →	IV	0,394		
IV: SM→	EE →	IV	0,305		

Based on Table 3 to analyze the first path can be explained that among the Financial Literacy (FL) with the Emotional Experience (EE) has a significant influence. It

can be known with the results of the significant value of 0,000 which is smaller than $\alpha = 0.05$. The second path between the Destination Image (DI) with the Emotional Experience (EE) has a significant influence namely of 0.002 which is smaller than $\alpha = 0.05$. The third path between Social Media (SM) with the Emotional Experience (EE) has significant influence that is equal to 0.007 which is smaller than $\alpha = 0.05$. A fourth path between Financial Literacy (FL) with Interest to Revisit (IrV) has a significant influence of 0.000 that is smaller than $\alpha = 0.05$. The fifth path between the Destination Image (DI) with Interest to Revisit (IrV) has significant influence that is equal to 0.002. The sixth path among the Social Media (SM) with Interest to Revisit (IrV) has significant influence that is equal to 0,007. The seventh path between Emotional Experience (EE) with Interest to Revisit (IrV) has significant influence of 0,010. The results of the path analysis can be seen in the following figure:

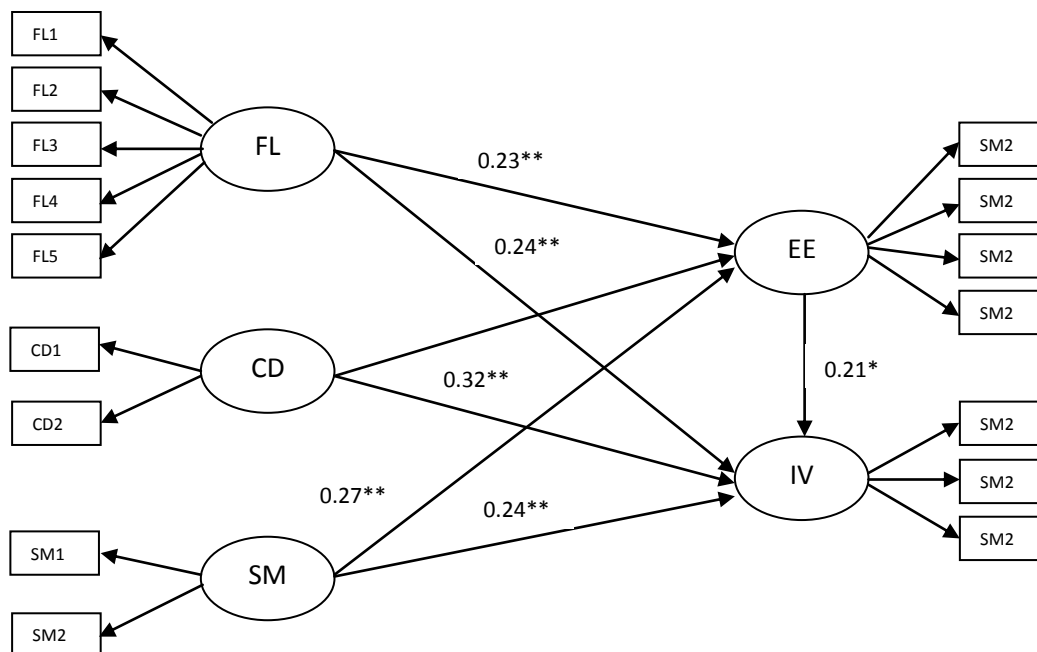

Figure 1: The Results of Path Analysis

Path coefficient was calculated by making structural equations that the regression equation that shows the relationship. Path analysis Model in equations is as follows:

$$EE = 2,421 + 0,231FL + 0,338DI + 0,273SM + e \quad \text{(Equation 1)}$$

$$IrV = 127 + 0,240FL + 0,321DI + 0,247SM + e \quad \text{(Equation 2)}$$

Based on Table 3 it can be seen that the significance Level (α) of the variable Financial Literacy (FL) is $0,000 < 0,05$. This means that the Financial Literacy (FL) have a significant effect on Emotional Experience (EE) (H_1 accepted). The level of significance (α) of the variable Destination Image is $0,002 < 0,05$. This means that the Destination Image significantly influence the Emotional Experience (H_2 accepted). Based on Table 3 it can be seen that the significance Level (α) of the variable Social Media is $0,007 < 0,05$.

This means that Social Media significantly influence the Emotional Experience (H_3 accepted).

The influence of Financial Literacy on Interest to Revisit indicate the level of significance (α) is $0,000 < 0,05$. This means that Financial Literacy significantly influence the Interest to Revisit (H_4 accepted). The level of significance (α) of the variable Destination Image is $0,002 < 0,05$. This means that the Destination Image significantly influence the Interest to Revisit (H_5 accepted). Similarly, the influence of Social Media on the Interest to Revisit indicate a significant effect on Interest to Revisit (H_6 accepted). On the other hand, the influence of Emotional Experience on Interest to Revisit can be seen that the significance Level (α) of variables of Emotional Experience is $0,010 < 0,05$. This means that the Emotional Experience significantly influence the Interest to Revisit (H_7 accepted).

4.2 Discussion

4.2.1 The influence of Financial Literacy on Emotional Experience and Interest to Revisit

The results of the path analysis on t Test against the first hypothesis (H_1) can be seen in Table 3 that the Financial Literacy of visitors influence the emotional experience by looking at the level of significance is equal to 0.000. The relationship indicated by the regression coefficient is positive, meaning that the better the knowledge about financial literacy of visitors then progressively boost the emotional experience (H_1 accepted). According to Rahma et al. (2016), visitor experience/customer experience is defined as experience obtained by the consumers either directly or indirectly regarding the process of service, the company, the facilities and how a consumer interacts with the company and with other consumers. This makes the response in cognitive, emotion and consumer behavior and leave the memories of consumers about the experience during and after the visit. This suggests that the ability of someone to manage his finances can affect the level of his emotional experience. It means, by the management on the income level of visitors in a certain amount for partially budgeted in terms of the needs for travelling, then the fulfillment of these needs can give the impression of a profound experience.

Based on the descriptive characteristics of respondents, visitors are mostly women aged 22-24 years old who are already married, and using a personal vehicle to go to Telaga Sarangan Natural Attraction from outside the city of Magetan aims to travel with family, visitors get a positive experience from the indicators of entertaining, educative, aesthetic, and escaping (Ye et al., 2019) at Wisata Telaga Sarangan and feel satisfied.

The influence of financial literacy on the interest to revisit show that the results of the path analysis on t Test against the fourth hypothesis (H_4) proved to be significant. That is, the level of knowledge of financial literacy will help visitors to manage their finances and provides an overview of the opportunities in order to achieve a better life in the future. Indicators of the dominant financial literacy of the

visitors to attract them to revisit is the price comparison/ticket please (Chen & Volpe, 1998; Lewis Mandell, 2008) before choosing which tourism will be addressed. This can be interpreted as the financial ability of visitors will have an impact on where they will be travelling back.

Based on the descriptive characteristics of respondents in table 1, from the intensity of the visit, the visitors often visit Telaga Sarangan Natural Attraction with the aim of travelling with family that is certainly gained experience as the beautiful natural landscape of Telaga Sarangan, the availability of the facilities that are educational such as picking strawberry, camping, farming, guaranteed with security for the facilities they will use, as well as the availability of variety of rides such as speed boat, horse riding. In addition, there is a tourist market that provides the visitors with Sarangan's typical present to be bought home, Sarangan's typical food such as rabbit satay, hotel or villa. The presence of such experience raises the sense of satisfaction so that visitors will come back to Telaga Sarangan Natural Attraction.

4.2.2 The influence of the Destination Image to the Emotional Experience and Interest to Revisit

The results of the path analysis on t Test against the second hypothesis (H₂) can be seen in Table 3 that the relationship indicated by the regression coefficient is positive, meaning that the better the destination image then the emotional experience will increase (H₂ accepted).

The image of destination according to Hanif et al. (2016) is a trust that is owned by a business regarding a product, service that tourists select, or will select. The image of destination is not always formed from experience or fact, but can be formed to be a factor of motivation or a strong driving force for the travel of tourists to a tourism destination. The image of destination consists of the rational assessment or the cognitive image and emotional assessment or affective image from the destination itself. The cognitive image explains the beliefs and information that a person has regarding a destination. There are six dimensions of the cognitive image, namely attractions, basic facilities, cultural attractions, accessibility and substructure of tourism, the natural environment, and economic factors. While the affective image is a picture of the emotions or feelings of a person which is the tourists' feeling about a destination.

Based on the descriptive characteristics of respondents, visitors mostly work as self-employed and visitors pay a visit to Telaga Sarangan Natural Attraction with the use of a personal vehicle as well as with the intensity of the visit 6-9 times, aims to travel with family. Variety of rides that are educative is one of the factors visitors come to Telaga Sarangan Natural Attraction, educational tourism such as picking strawberry, camping, and etc., both provide lessons to children and families to realize the importance of the activities in the nature. By the repeated intensity of the visits, it is known that visitors have the emotional experience to the Telaga Sarangan Natural Attraction to be selected as a place for holiday; it reflects the satisfaction of visitors to Telaga Sarangan Natural Attraction in Magetan Regency.

The image of destination affects the interest to revisit by seeing the level of significance that is equal to 0.002. The relationship indicated by the regression coefficient is positive, meaning that the better the Image of Destination then the Interest to Revisit will be increased (H_5 accepted). The image of destination according to Hanif et al. (2016) is a trust that is owned by a business regarding a product or service that tourists will choose. Destination image is not always formed from experience or facts but can be formed, so that it becomes a factor of motivation or a strong driving force for the travel of tourists to a tourism destination. Destination image based on the assessment of tourists can be vary between one person to another. Destination image consists of the rational assessment or cognitive image and emotional assessment or affective image from the destination itself. The cognitive image explains the beliefs and information that a person has regarding a destination. There are six dimensions of cognitive image, namely attractions, basic facilities, cultural attractions, accessibility and substructure of tourism, the natural environment, and economic factors. While the affective image is a picture of the emotions or feelings of a person which is the tourists' feeling about a destination. The affective image is divided into three, namely city of the living (lively city), the city that makes us excited (exiting city), and the city that makes us pleased (pleasant city).

The results of this study are in line with previous research which states that the Image of Destination has a positive effect on the Interest to Revisit. Based on the descriptive characteristics of the respondents, it is known that the visitors have trust in Telaga Sarangan Natural Attraction to be selected as a place traveled to, the trust arises because of the emotional experience of visitors to Telaga Sarangan Natural Attraction in Magetan Regency. The intensity of visits is high, ranging between 6-9 times to show tourists have the emotional experience with the destination, with the view of nature as well as the facilities that are available then the tourists get an overview of the emotions or feelings about Telaga Sarangan Natural Attraction because of habit or because of the destination is close to their residence so that visitors revisit it. Based on previous research it is known that the Image of Destination has a positive effect on the Interest to Revisit Telaga Sarangan Natural Attraction in Magetan Regency.

4.2.3 The influence of Social Media on Emotional Experience and Interest to Revisit

Social Media is online content created using the technology of publishing a very easy and scalable, the most important of these technologies is the shift in ways of knowing people, read and share stories and find information and content. Social Media has a lot of applications that provide travel information such as Trip Advisor, Instagram, Facebook, official website of city, the travel blogger, which facilitate the tourists to obtain information about the travel destination. Social Media also affect the tourists' decision to travel by a post from their friends/family about travel information in the form of video, pictures, and text.

Based on the descriptive characteristics of respondents in table 1, that the visitors can easily access social media, because most of the visitors are bachelor who of course

understand about the technology, with the intensity of the visits that are repeated then it can be said that the visitors are satisfied with Telaga Sarangan Natural Attraction. From social media, visitors can see promotions or information about Telaga Sarangan and come to the site in accordance with the information provided on social media. Based on previous research it is known that Social Media has a positive effect on emotional experience in Telaga Sarangan Natural Attraction in Magetan Regency.

The influence of social media against the interest to revisit can be proved. The relationship indicated by the regression coefficient is positive, meaning that the better the social media in informing the tourist destination then the interest to revisit will be increased (H_6 accepted). Social Media is a means for consumers to share information-text, image, audio, and video- with each other and with companies and vice versa. The Internet has been shaping time and space (Hamzah, 2013; Kotler & Armstrong, 1978; Kotler & Keller, 2016). The internet network is a very helpful for a person in communication directly with various communities in the entire world without being limited by distance and time, one of them is through social media. Social Media has a lot of applications that provide travel information. Social Media also affect the tourists' decision to travel by a post from their friends/family about travel information in the form of video, pictures, or destination review.

The results of this study are in line with previous research conducted by Setiyaningtiyas & Hasan (2015) stating that Social Media has a positive effect on the interest to revisit. Based on the descriptive characteristics of respondents, visitors can easily access social media, because most of the visitors is a bachelor that is of course aware of the technology, with the intensity of the visits that are repeated then it can be said that the visitors are satisfied with Telaga Sarangan Natural Attraction. Social media makes it easy for visitors to be able to see promotions or information about Telaga Sarangan. At the time of the visitors visit the destination that is accordance with the information provided in social media, then visitors will feel satisfied with Telaga Sarangan Natural Attraction thereby forming the emotional experience of visitors. Thus, visitors will revisit the destination. Based on previous research it is known that Social Media has a positive effect on the interest to revisit Telaga Sarangan Natural Attraction in Magetan Regency.

4.2.4 The Influence of Emotional Experience on the Interest to Revisit

The results of the path analysis on t Test against the hypothesis seven (H_7) can be seen in Table 3 that the emotional experience affect the interest to revisit by the level of significance amounting to 0,010. The relationship indicated by the regression coefficient is positive, meaning that the higher the emotional experience of visitors then the interest to revisit is increasing (H_7 accepted). With the customer experience, customers will be able to distinguish the products and services one with the other because they can feel and gain experience directly through five approaches (sense, feel, think, act, relate), both before and when they consume a product or service. The results of this

study are in line with previous studies which stated that emotional experience has a positive effect on interest to revisit (Setiyaningtiyas & Hasan, 2015; Ye et al., 2019).

A reflection of the emotional experience are indicators of entertaining, educative, aesthetic, and escaping (Ye et al., 2019), that are associated at the pleasure of the hedonist during in the tourist areas. Geographically, Telaga Sarangan Natural Attraction is located at the foot of Mount Lawu in Ngerong Village, Plaosan District, Magetan Regency where the natural landscape and the lake looks beautiful, equipped with strawberry garden, as well as the arena of horse riding. A wide variety of typical food of the area, souvenir markets, fresh vegetable market, speed boat rides and the other being a complement of services for tourists. Travelers are pampered with a view of the beautiful lake, the fresh air while you eat the food that is available. So, it is this that forms the strength of emotional experience in influencing tourists to revisit Telaga Sarangan Natural Attraction.

4.3 Recommendations

Expected for manager or industry manager of Telaga Sarangan Natural Attraction and industry manager of other natural tourism destination to improve the marketing strategy which is better than before by improving the quality of service tourist rides. Keeping and maintaining the authenticity, beauty, and cleanliness of tourist areas is a necessity for managers of natural tourism. This is the power to build emotional experience that creates the desire of tourists to revisit in the future.

Things that need to be done by the Local Government is doing the synergy between the businesses of tourism management, hospitality industry, providers of transportation services, as well as the community through community-based development as well as involving academics to develop the tourism sector.

5. Conclusion

Based on the results of the analysis and discussion it can be concluded that the visitor's financial literacy, the image of destination, and social media significantly influence the emotional experience. In addition, the visitor's financial literacy, the image of destination, and social media also directly affects in the increase of interest to revisit the destination. Emotional experience is a significant effect on the interest to revisit the destination. The direction of the relationship of emotional experience in a positive manner can increase the visitor's interest to revisit Telaga Sarangan Natural Attraction.

About the Author(s)



Ika Barokah Suryaningsih, the history of education began from the undergraduate study in Department of Management Faculty of Economics University of Jember class of 1997 and possessed a bachelor title in 2001. Pass graduate school and got the master title from Study Program of Master Degree of Management University of Jember in 2003. Graduated from the Doctoral Program of Management Science in 2014, interest in Marketing Management at the Faculty of Economics and Business University of Brawijaya Malang. During the doctoral study in 2013, get the scholarship from directorate general of higher education for the program PKPI (Sandwich-like Program) at The University of Queensland Australia.

In 2001 worked as financial administration personnel for IMKI Prima, Jember Branch office, in 2002 worked as employees of PT. Adira Dinamika Multi Finance, and since 2003 until now worked as a lecturer in the Department of Management Faculty of Economics and Business University of Jember. Since 2014-2019 active as the Chairman of the S1 Management Study Program and member of Cluster Quality Assurance of the Faculty of Economics and Business, University of Jember. In addition to teaching and conducting marketing research is also active as Chairman of the Research Group “*Tourism Management and Community Development (RISMA CODE)*”, and active as one of the authors of the opinion column for the Radar Jember Daily Newspaper in a wide variety of topics from other social sciences.

Some of the works already published is a book: *Six Sigma: The Study of the Theory and Application Research on Banking Services*, this book is the result of Competitive Research Grants on funded by DP2M DIKTI in 2009. Furthermore, as one of the authors of the book of *Potpourri: The Strategy of International Management* published in 2012. The next book is a book titled: *Trust vs. Perceived Risk: A Review of Theory and Empirical Purchase Decision of B2B Products Import*, this book is also born from the results of funding Research Grants Doctoral Dissertation DP2M DIKTI in 2013.

References

- Bora, B., Bilgihan, A., Haobin, B., Buonincontri, P., & Okumus, F. (2018). International Journal of Hospitality Management The impact of servicescape on hedonic value and behavioral intentions : The importance of previous experience. *International Journal of Hospitality Management*, 72(April 2017), 10–20. <https://doi.org/10.1016/j.ijhm.2017.12.007>
- Chen, H., & Volpe, R. (1998). An Analysis of Personal Literacy of Personal Literacy among College Students. *Financial Services Review*, 7(2), 107–128.

- Chieh, Y., King, B., & Lee, H. (2018). Journal of Destination Marketing & Management Experiencing the destination brand: Behavioral intentions of arts festival tourists. *Journal of Destination Marketing & Management*, 10(June), 61–67. <https://doi.org/10.1016/j.jdmm.2018.06.004>
- Everitt, B., & Hothorn, T. (2011). *An Introduction to Applied Multivariate Analysis with R*. <https://doi.org/10.1007/978-1-4419-9650-3>
- Ferdinand, A. (2006). *Metode Penelitian Manajemen*. Semarang: Badan Penerbit Universitas Diponegoro.
- Frederick, A., & Hariwan, P. (2016). Analisis Pengaruh Customer Experience Terhadap Minat Beli Ulang Pada Wiki Koffie Bandung. *E- Proceeding of Management*, 1(1).
- Hamzah, Y.I. (2013). Potensi Media Sosial Sebagai Sarana Promosi Interaktif Bagi Pariwisata Indonesia. *Jurnal Kepariwisata Indonesia*, 8(3), 1–9. Retrieved from [http://www.kemenpar.go.id/userfiles/JKI_Vol_8_No_3_2013 - Potensi Media Sosial Sebagai Sarana Promosi Interaktif Bagi Pariwisata Indonesia](http://www.kemenpar.go.id/userfiles/JKI_Vol_8_No_3_2013_-_Potensi_Media_Sosial_Sebagai_Sarana_Promosi_Interaktif_Bagi_Pariwisata_Indonesia)
- Hanif, A., Kusumawati, A., & Mawardi, K. (2016). Pengaruh Citra Destinasi Terhadap Kepuasan Wisatawan Serta Dampaknya Terhadap Loyalitas Wisatawan Studi Pada Wisatawan Nusantara Yang Berkunjung Ke Kota Batu. *Jurnal Administrasi Bisnis (JAB)*, 3(1).
- Hawkins, B., & Coney. (2001). *Consumer Behavior: Building Marketing Strategy*. USA: Mc Graw-Hill.
- Kotler, P. (2000). Marketing Management, Millennium Edition. *Marketing Management, Millennium Edition*, 23(6), 188–193. [https://doi.org/10.1016/0024-6301\(90\)90145-T](https://doi.org/10.1016/0024-6301(90)90145-T)
- Kotler, P., & Armstrong, G. (1978). Principles of Marketing Channel Management. *Journal of Marketing*, 42(4), 105. <https://doi.org/10.2307/1250103>
- Kotler, P., & Keller, K.L. (2016). *Marketing Management 15 Global Edition*. <https://doi.org/10.1080/08911760903022556>
- L Remund, D. (2010). Financial Literation Explicated: The Case for a Clearer Definition in an Increasingly Complex Economy. *Journal of Consumer Affair*, 4, 276–295.
- Mandell, L. (2008). The financial literacy of young {American} adults. Retrieved on January, 13, 1013. https://doi.org/10.1007/978-0-387-75734-6_10
- Mandell, L., & K. Klein, L. (2007). Motivation and Financial Literation. *Financial Services Review*, 105–116.
- Rahma, M., Andari, R., & Yuniawati, Y. (2016). Pengaruh Customer Experience Terhadap Behavioral Intention Wisatawan di Saung Angklung Udjo. *Tourism and Hospitality Essential (THE) Journal*, 6(2).
- Setiyaningtiyas, N.W., & Hasan, A. (2015). . Pengaruh Elektronik Word Of Mouth Pada Media Sosial Facebook Terhadap Keputusan Berkunjung Ke Desa Wisata Nglanggeran Gunungkidul. *Jurnal Media Wisata*, 13(1).
- Sugiyono. (2008). *Metodologi Penelitian Kualitatif, kuantitatif*. Bandung: CV. Alfabeta.
- Wakefield, L.T., & Wakefield, R.L. (2018). Anxiety and Ephemeral Social Media Use in Negative eWOM Creation. *Journal of Interactive Marketing*, 41, 44–59. <https://doi.org/10.1016/j.intmar.2017.09.005>

- Wibowo, S.F., Sazali, A., & Rivai, A.K. (2016). The Influence of Destination Image and Tourist Satisfaction toward Revisit Intention of Setu Babakan Betawi Cultural Village. *Jurnal Riset Manajemen Sains (JRMSI)*, 7(1).
- Wicaksono, A. (2017). Pengaruh media sosial instagram @wisatadakwahokura terhadap minat berkunjung followers. *JOM FISIP*, 4(2).
- Ye, S., Xiao, H., & Zhou, L. (2019). Small accommodation business growth in rural areas: Effects on guest experience and financial performance. *International Journal of Hospitality Management*, 76(December 2017), 29–38. <https://doi.org/10.1016/j.ijhm.2018.03.016>
- Ying, T., Wei, W., Wen, J., Wang, L., & Ye, S. (2018). Journal of Destination Marketing & Management Chinese cigar tourists to Cuba : A motivation-based segmentation. *Journal of Destination Marketing & Management*, 10(April), 112–121. <https://doi.org/10.1016/j.jdmm.2018.07.003>
- Yuni, Y., & Finardi, A.D.I. (2016). . Pengaruh Customer Experience Terhadap Revisit Intention di Taman Wisata Alam Gunung Tangkuban Perahu. *Tourism and Hospitality Essentials (THE) Journal*, 6(1).
- Zatori, A., Smith, M.K., & Puczko, L. (2018). Experience-involvement , memorability and authenticity : The service provider ' s effect on tourist experience. *Tourism Management*, 67, 111–126. <https://doi.org/10.1016/j.tourman.2017.12.013>

Ika Barokah Suryaningsih, Sumani
THE INFLUENCE OF FINANCIAL LITERACY, THE IMAGE OF DESTINATION,
THE SOCIAL MEDIA AGAINST THE INTEREST OF VISITING LOCAL TOURISTS THROUGH
THE MEDIATION OF THE EMOTIONAL EXPERIENCE

Creative Commons licensing terms

Authors will retain copyright to their published articles agreeing that a Creative Commons Attribution 4.0 International License (CC BY 4.0) terms will be applied to their work. Under the terms of this license, no permission is required from the author(s) or publisher for members of the community to copy, distribute, transmit or adapt the article content, providing a proper, prominent and unambiguous attribution to the authors in a manner that makes clear that the materials are being reused under permission of a Creative Commons License. Views, opinions and conclusions expressed in this research article are views, opinions and conclusions of the author(s). Open Access Publishing Group and European Journal of Management and Marketing Studies shall not be responsible or answerable for any loss, damage or liability caused in relation to/arising out of conflict of interests, copyright violations and inappropriate or inaccurate use of any kind content related or integrated on the research work. All the published works are meeting the Open Access Publishing requirements and can be freely accessed, shared, modified, distributed and used in educational, commercial and non-commercial purposes under a [Creative Commons Attribution 4.0 International License \(CC BY 4.0\)](https://creativecommons.org/licenses/by/4.0/).